

# VGA8000 Flanged Globe Valve



# VGA8000 Series Flanged Globe Valve



2-way Flanged VGA82xx Series



3-way Flanged VGA88/89xx Series

## Features

- 1: DN15 to DN250 available
- 2: Kvs 0.63 to 700 m<sup>3</sup>/h
- 3: High-grade ductile iron QT450-10 for valve body
- 4: Standard flange connection of ISO7005-2
- 5: Fitted with VAP-B, VAF series actuator with various  $\Delta P$  available for different applications

## Technical Data

<b>Rated pressure</b>	PN16
<b>Flange connection</b>	ISO7005-2
<b>Media</b>	Water, glycol solutions (<50%), low pressure steam (<100kPa)
<b>Temperature range</b>	-25~150°C
<b>Valve Characteristics</b>	DN25~80 equal percentage at full range
	DN15~20, DN100~250 equal percentage at 0~40%, modified equal percentage at 40~100%
	For 3-Way bypass port, Linear at all sizes and opening
<b>Leakage rage</b>	0.01% of Kvs
<b>Rangibility</b>	>50:1

Note: When media temperature is below 2°C, a stem heater is required. Please order "VGA-H1" for DN15 to DN65 while "VGA-H2" for DN80 to DN250.





## Material

<b>Valve body</b>	Ductile iron of QT450-10
<b>Valve trim</b>	Stainless steel
<b>Valve stem</b>	Stainless steel
<b>Sealing structure</b>	V model sealing gland + stainless steel spring self-compensation
<b>Stem sealing</b>	PTFE

## Model List





Size	2-way	3-way mixing	3-way diverting	Stroke (mm)	Kvs (m <sup>3</sup> /h) at control port	Kvs (m <sup>3</sup> /h) at bypass port (for 3-way only)
DN15	VGA8201AC	VGA8803AC	VGA8903AC	20	0.63	0.4
	VGA8201AD	VGA8803AD	VGA8903AD	20	1	0.63
	VGA8201AE	VGA8803AE	VGA8903AE	20	1.6	1
	VGA8201AF	VGA8803AF	VGA8903AF	20	2.5	1.6
	VGA8201AG	VGA8803AG	VGA8903AG	20	4	2.5
DN20	VGA8201BL	VGA8803BL	VGA8903BL	20	6.3	4
DN25	VGA8201CN	VGA8803CN	VGA8903CN	20	10	6.3
DN32	VGA8201DP	VGA8803DP	VGA8903DP	20	16	10
DN40	VGA8201ER	VGA8803ER	VGA8903ER	20	25	16
DN50	VGA8201FS	VGA8803FS	VGA8903FS	20	40	25
DN65	VGA8201GT	VGA8803GT	VGA8903GT	20	63	40
DN80	VGA8201HU	VGA8803HU	VGA8903HU	30	100	63
DN100	VGA8201JV	VGA8803JV	VGA8903JV	40	160	100
DN125	VGA8201NW	VGA8803NW	VGA8903NW	40	250	160
DN150	VGA8201PX	VGA8803PX	VGA8903PX	40	350	220
DN200	VGA8201RY	VGA8803RY	VGA8903RY	40	520	330
DN250	VGA8201SZ	VGA8803SZ	VGA8903SZ	40	700	475

## ΔP with Actuator

VGA8200 DN15-DN250 Globe Valves			Non Spring Return								
			VAx500		VAx1000		VAx1800		VAx3000		
											
			On/Off, Floating 24V 0 (2) to 10 VDC 0 (4) to 20 mA	On/Off, Floating 220V	On/Off, Floating 24V 0 (2) to 10 VDC 0 (4) to 20 mA	On/Off, Floating 220V	On/Off, Floating 24V 0 (2) to 10 VDC 0 (4) to 20 mA	On/Off, Floating 220V	On/Off, Floating 24V 0 (2) to 10 VDC 0 (4) to 20 mA	On/Off, Floating 220V	On/Off, Floating 24V 0 (2) to 10 VDC 0 (4) to 20 mA
Auxiliary Switch											
Voltage output							■		■		■
Position Feedback											
0(2) to 10 VDC and 0(4) to 20 mA				■		■		■		■	
Power Requirement											
220 VAC +/-15% 50/60 Hz				■		■		■		■	
24 VAC +/-15% 50/60 Hz			■	■	■	■	■	■	■	■	■
Electrical Connections											
Screw terminal			■	■	■	■	■	■	■	■	■
Accessories											
Manual operation			■	■	■	■	■	■	■	■	■
DN	Kvs	2-way	Close-Off Pressure (kPa)								
DN15	0.63	VGA8201AC	<b>1600</b>	1600	1600	1600	1600	1600	1600	1600	
DN15	1	VGA8201AD	<b>1600</b>	1600	1600	1600	1600	1600	1600	1600	
DN15	1.6	VGA8201AE	<b>1600</b>	1600	1600	1600	1600	1600	1600	1600	
DN15	2.5	VGA8201AF	<b>1600</b>	1600	1600	1600	1600	1600	1600	1600	
DN15	4	VGA8201AG	<b>1600</b>	1600	1600	1600	1600	1600	1600	1600	
DN20	6.3	VGA8201BL	<b>1100</b>	1600	1600	1600	1600	1600	1600	1600	
DN25	10	VGA8201CN	<b>700</b>	800	1600	1600	1600	1600	1600	1600	
DN32	16	VGA8201DP	<b>400</b>	600	1600	1600	1600	1600	1600	1600	
DN40	25	VGA8201ER	<b>250</b>	<b>450</b>	1600	1600	1600	1600	1600	1600	
DN50	40	VGA8201FS		<b>300</b>	600	1600	1600	800	1600	1600	
DN65	63	VGA8201GT			<b>450</b>	1600	1600	600	1600	1600	
DN80	100	VGA8201HU			<b>300</b>	1600	1600	450	1600	1600	
DN100	160	VGA8201JV			<b>1600</b>	1600	1600	1600	1600	1600	
DN125	250	VGA8201NW			<b>1600</b>	1600	1600	1600	1600	1600	
DN150	350	VGA8201PX			<b>1600</b>	1600	1600	1600	1600	1600	
DN200	520	VGA8201RY						<b>1600</b>	1600	1600	
DN250	700	VGA8201SZ							<b>1600</b>	1600	
Linkage			None								
VAF500-24-B			None								
VAP500-24-B			None								
VAF500-220-B			None								
VAF1000-24-B			None								
VAP1000-24-B			None								
VAF1000-220-B			None								
VAF1800-24-B			None								
VAP1800-24-B			None								
VAF1800-220-B			None								
VAF3000-24-B			None								
VAP3000-24-B			None								
VAF3000-220-B			None								

Bold numbers for close-off pressure indicate preferred value for HVAC application.



VGA8800-VGA8900 DN15-DN250 Globe Valves				Non Spring Return											
				VAx500		VAx1000		VAx1800		VAx3000					
															
				On/Off, Floating 24V 0 (2) to 10 VDC 0 (4) to 20 mA	On/Off, Floating 220V	On/Off, Floating 24V 0 (2) to 10 VDC 0 (4) to 20 mA	On/Off, Floating 220V	On/Off, Floating 24V 0 (2) to 10 VDC 0 (4) to 20 mA	On/Off, Floating 220V	On/Off, Floating 24V 0 (2) to 10 VDC 0 (4) to 20 mA	On/Off, Floating 220V	On/Off, Floating 24V 0 (2) to 10 VDC 0 (4) to 20 mA	On/Off, Floating 220V		
<b>Auxiliary Switch</b>															
Voltage output								■	■	■	■				
<b>Position Feedback</b>															
0(2) to 10 VDC and 0(4) to 20 mA				■		■		■		■					
<b>Power Requirement</b>															
220 VAC +/-15% 50/60 Hz					■		■		■		■				
24 VAC +/-15% 50/60 Hz				■	■	■	■	■	■	■	■				
<b>Electrical Connections</b>															
Screw terminal				■	■	■	■	■	■	■	■				
<b>Accessories</b>															
Manual operation				■	■	■	■	■	■	■	■				
DN	Kvs	3-way Mixing	3-way Diverting	<b>Close-Off Pressure (kPa)</b>											
DN15	0.63	VGA8803AC	VGA8903AC	<b>800</b>	1100	1600									
DN15	1	VGA8803AD	VGA8903AD	<b>800</b>	1100	1600									
DN15	1.6	VGA8803AE	VGA8903AE	<b>800</b>	1100	1600									
DN15	2.5	VGA8803AF	VGA8903AF	<b>800</b>	1100	1600									
DN15	4	VGA8803AG	VGA8903AG	<b>800</b>	1100	1600									
DN20	6.3	VGA8803BL	VGA8903BL	<b>800</b>	1100	1600									
DN25	10	VGA8803CN	VGA8903CN	<b>800</b>	1100	1600									
DN32	16	VGA8803DP	VGA8903DP	<b>800</b>	1100	1600									
DN40	25	VGA8803ER	VGA8903ER	<b>800</b>	1100	1600									
DN50	40	VGA8803FS	VGA8903FS		<b>300</b>	600		800							
DN65	63	VGA8803GT	VGA8903GT			<b>450</b>		600							
DN80	100	VGA8803HU	VGA8903HU			<b>270</b>		450							
DN100	160	VGA8803JV	VGA8903JV					<b>200</b>							
DN125	250	VGA8803NW	VGA8903NW					<b>150</b>							
DN150	350	VGA8803PX	VGA8903PX					<b>100</b>							
DN200	520	VGA8803RY	VGA8903RY					<b>80</b>							
DN250	700	VGA8803SZ	VGA8903SZ					<b>50</b>							
<b>Linkage</b>				None											
				VAF500-24-B	VAP500-24-B	VAF500-220-B	VAF1000-24-B	VAP1000-24-B	VAF1000-220-B	VAF1800-24-B	VAP1800-24-B	VAF1800-220-B	VAF3000-24-B	VAP3000-24-B	VAF3000-220-B

Bold numbers for close-off pressure indicate preferred value for HVAC application.

## Mechanical Design

2-way VGA82xx:

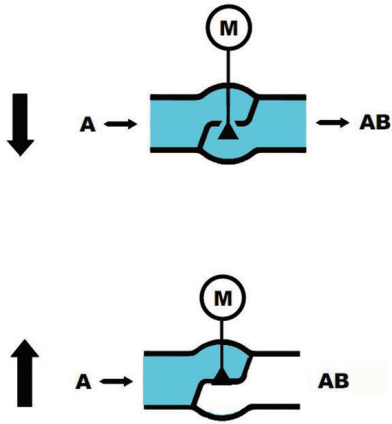

3-way VGA88xx/89xx:

DN15-DN65	VGA88... 3-Way Mixing	VGA89... 3-Way Diverting	/
DN80-DN250		/	VGA89... 3-Way Diverting
↓			
↑			
	Mixing 	Diverting 	Diverting 

## Flow Characteristic

A - AB: DN25-DN80, Equal percentage  
 DN15-20, DN100-250, Equal percentage at 0-40%,  
 while modified equal percentage at 40-100%;

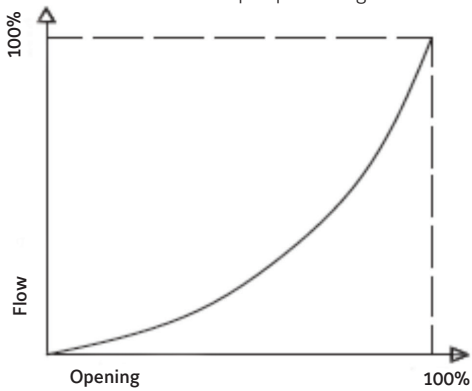

B - AB: Linear

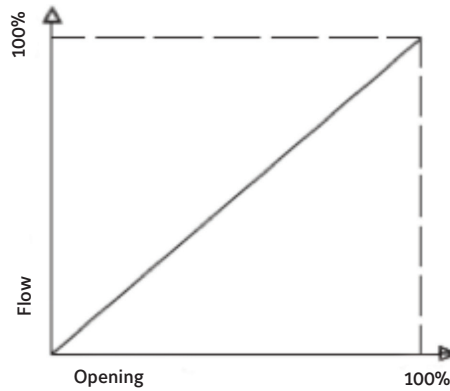

## Accessory (Stem Heater)



VGA-H1/H2 Stem Heater

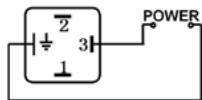

Wiring Diagram

Model	Stroke	Power Supply	Power Consumption	Heating Temperature
VGA-H1	20mm	24VAC/DC	15w	80-120 C
VGA-H2	30mm/40mm	24VAC/DC	15w	80-120 C



Install the terminal on actuator as indicated on picture



Note: the side with "24V 15W" shall be placed to face down

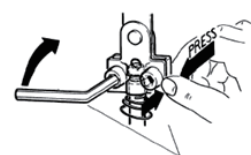
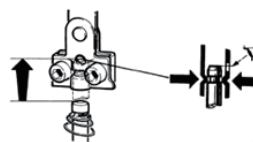

## Installation

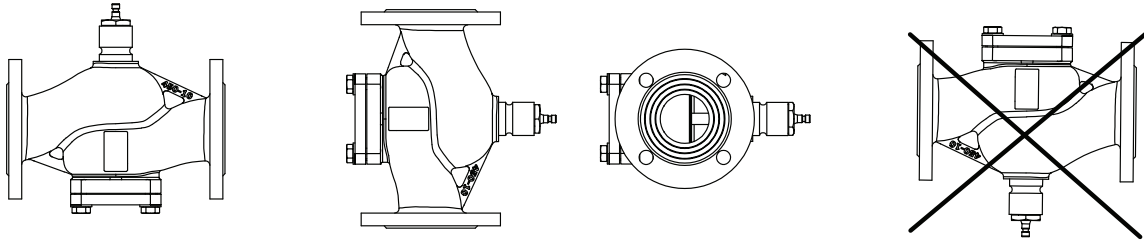

- The valves are to be installed by skilled personnel and in strict accordance with the installation instructions and local regulations. Johnson Controls assumes no responsibility for damages or injuries resulting from non-compliance with installation instructions or standard good practice when mounting, operating or maintaining the valve, even if not explicitly mentioned herein.
- The valve and the pipes must be free of dirt, welding beads, etc.
- The valves are designed for a fluid temperature range, flow direction, as well as for a maximum pressure, as shown in this installation instruction.
- There should be no mechanical tension in the pipe work when the valve is fitted.

## Dimensions

2-way VGA82xx:

3-way VGA88xx/89xx:

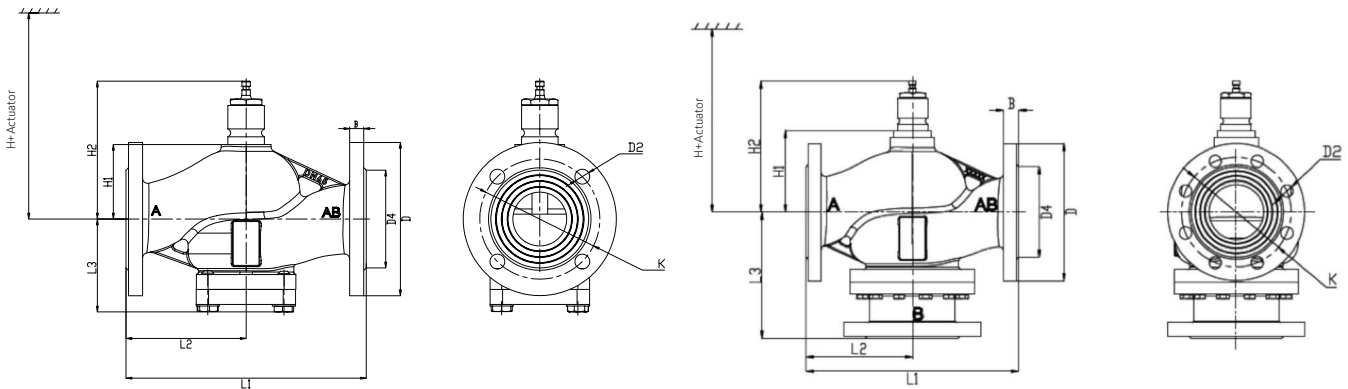

DN	B mm	D mm	D2 mm	D4 mm	K mm	L1 mm	L2 mm	L3 mm 2-way	L3 mm 3-way	H1 mm	H2 mm	Weight kg 2-way	Weight kg 3-way	H-1 mm	H-2 mm
15	14	95	4-14	46	65	130	65	70	106	41	117	3.6	4.5	395	656
20	16	105	4-14	56	75	150	75	70	106	46	122	4.6	5.7	400	661
25	16	115	4-14	65	85	160	80	75	111	48	124	5.2	6.3	402	663
32	18	140	4-19	76	100	180	90	80	121	59	135	7.4	9.4	413	674
40	18	150	4-19	84	110	200	100	82	122	50	126	9.4	11.7	404	665
50	20	165	4-19	99	125	230	115	98	136	60	136	13	15.6	414	675
65	20	185	4-19	118	145	290	145	112	156	90	166	20	24	/	705
80	22	200	8-19	132	160	310	155	130	185	120	196	31	34	/	735
100	23	220	8-19	156	180	350	175	150	202	136	212	46	49	/	751
125	24	250	8-19	184	210	400	200	175	240	157	233	59	63	/	772
150	25	285	8-23	211	240	480	240	200	270	171	247	77	82	/	786
200	26	340	12-23	266	295	500	250	238	315	185	261	122	129	/	800
250	31	405	12-28	319	55	600	300	264	370	205	281	185	195	/	820

Note: H-1 for 500N/1000N Actuator, H-2 for 1800N/3000N Actuator

Johnson Controls (JCI) is a global diversified technology and industrial leader serving customers in more than 150 countries. Our 150,000 employees create quality products, services and solutions to optimize energy and operational efficiencies of buildings; lead-acid automotive batteries and advanced batteries for hybrid and electric vehicles; and seating components and systems for automobiles. Our commitment to sustainability dates back to our roots in 1885, with the invention of the first electric room thermostat.

Johnson Controls Building Efficiency delivers products, services and solutions that increase energy efficiency and lower operating costs in buildings for more than one million customers worldwide. Operating from 500 locations globally, the company is committed to growing the BE business. In 2014, we acquired Air Distribution Technologies and in 2015, we obtained a majority stake in the joint venture with Hitachi Appliances.

**Australia**

Tel : +61 (2) 9805 8300  
Fax: +61 (2) 9889 3016

**China (Shanghai)**

Tel : +86 (21) 6276 6509  
Fax: +86 (21) 6277 3543

**Hong Kong**

Tel : +852 2590 0012  
Fax: +852 2516 5648

**India (Mumbai)**

Tel : +91 (22) 6683 7000  
Fax: +91 (22) 6683 7002

**Indonesia**

Tel : +62 (21) 5366 8500  
Fax: +62 (21) 5366 8300

**Japan**

Tel : +81 (3) 5738 6100  
Fax: +81 (3) 5738 6298

**Korea**

Tel : +82 (2) 554 5935  
Fax: +82 (2) 554 5739

**Macau**

Tel : +853 2875 1820  
Fax: +853 2875 1825

**Malaysia**

Tel : +60 (3) 7628 4393  
Fax: +60 (3) 7620 0538

**New Zealand**

Tel : +64 (9) 444 6434  
Fax: +64 (9) 444 2092

**Singapore**

Tel : +65 6748 0202  
Fax: +65 6284 3017

**Thailand**

Tel : +66 (2) 717 1260-80  
Fax: +66 (2) 717 0861

**Asia Engineering Centre: Wuxi, China**

**Shanghai Distribution Center: Shanghai, China**

**Asia Centre of Excellence in Engineering (CoEE): Beijing, China · Mumbai & Pune, India**

**Manufacturing/Assembly: Guangzhou & Wuxi, China · Pune, India**

